

Solar Collector Factsheet

Geosolair Geosolair SOLARHEAT 15/18



Model	Geosolair SOLARHEAT 15/18
Type	Evacuated tube collector
Manufacturer	Geosolair Limited
Address	Drivers Wharf Northam Road UK-SO14 0PF Southampton
Telephone	+44 (0)2380 382825
Fax	--
Email	sales@geosolair.co.uk
Internet	www.geosolair.co.uk
Test date	07.2009

- Performance test EN12975:2006
- Quality test EN12975:2006

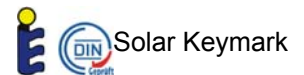

Dimensions

Total length	1.986 m
Total width	1.184 m
Gross area	2.351 m ²
Aperture area	1.393 m ²
Absorber area	1.224 m ²
Weight empty	52 kg

Technical data

Minimum flowrate	80 l/h
Nominal flowrate	600 l/h
Maximum flowrate	720 l/h
Fluid content	0.9 l
Maximum operating pressure	6 bar
Stagnation temperature	212 °C

Types of mounting

- Construction for sloping roof
- Integration into sloping roof
- On flat roof with stand
- Facade

Further information

- Units in different sizes available
- Glazing replaceable

Hydraulic connection

Copper pipe, nominal diameter 22 mm

Construction

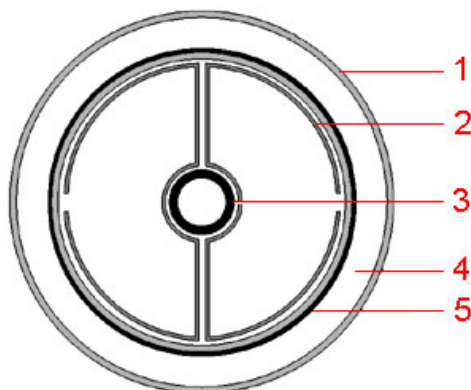

- 1 Glazing
- 2 Heat-conducting metal sheet
- 3 Heat pipe
- 4 Vacuum
- 5 Absorber

Peak Power per collector unit W_{peak}

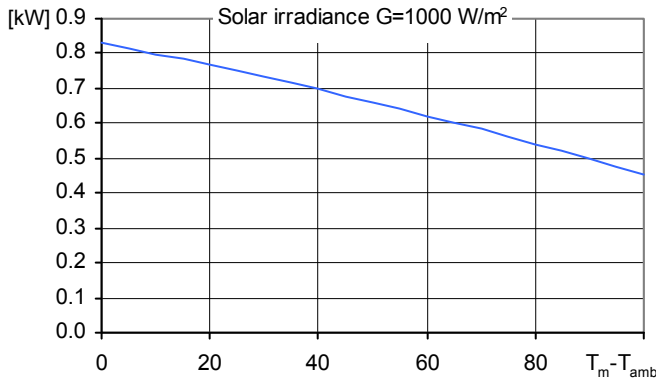

Peak Power W_{peak}	831 W
Thermal capacity*	18.4 kJ/K
Flowrate during test	159 l/h
Fluid for test	Water-Glycol 33.3%

Relative efficiency η

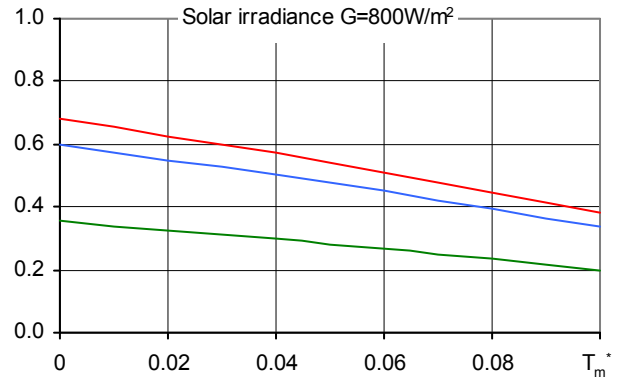

Reference	Gross	Aperture	Absorber
η_0	0.354	0.597	0.679
a_1 [$WK^{-1}m^{-2}$]	1.32	2.22	2.53
a_2 [$WK^{-2}m^{-2}$]	0.0028	0.0047	0.0054

*) Specific thermal capacity C of the collector without fluid, determined according to 6.1.6.2 of EN12975-2:2006

Incident angle modifier IAM

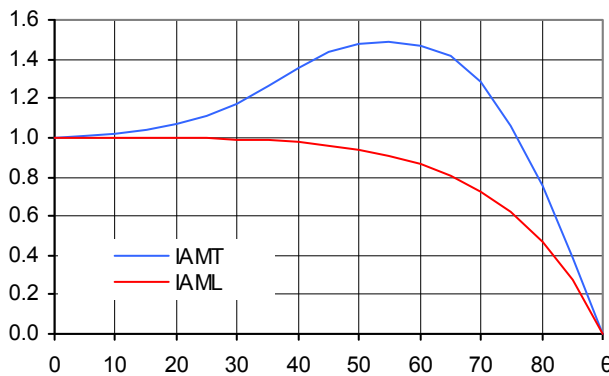

K1, transversal IAM at 50°	1.48
K2, longitudinal IAM at 50°	0.94

Pressure drop Δp

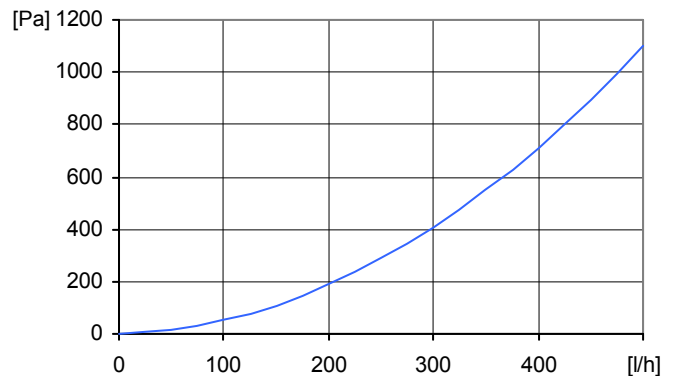

Pressure drop at nominal flowrate
 $\Delta p = 1572$ Pa (T=20°C)

SPF Simulation of systems using Polysun

Short description of the system

Climate: Central Switzerland, orientation of the collectors: South,
Cold water 10°C, Hot water 50°

Domestic hot water: $F_{ss}^* = 60\%$

Tank 450 l, collector inclination 45°,
Daily energy demand 10 kWh (4-6 persons)
Energy demand of the reference system 4200 kWh/year

Water pre-heating: $F_{ss}^* = 25\%$

2 Tanks: 1500 l & 2500 l, collector inclination 30°,
Domestic hot water consumption 10'000 l/day (200 persons)
Daily heat losses (circulation and tanks) 60 kWh,
Energy demand of the reference system 191'700 kWh/year

Space heating system: $F_{ss}^* = 25\%$

Combined storage 1200 l, collector inclination 45°,
Daily energy demand 10 kWh (4-6 persons), Building 200 m², moderately
heavy construction, well insulated, Heating power demand 5.8 kW (ambient
temperature -8°C), Energy demand space heating 12140 kWh/year,
Energy demand of the reference system 16340 kWh/year

Surface demand**
Number of collectors

Solar yield**

5.18 m²
3.7 collectors 493 kWh/m²

68.4 m²
49.1 collectors 702 kWh/m²

15.2 m²
10.9 collectors 359 kWh/m²

*) Fractional solar savings: Proportion of the final energy that, thanks to the solar system, can be saved compared to a reference system.
**) Surface demand and solar yield are given with respect to the aperture area.